



● 用途 Applications

高效沉淀器属沉淀分离装置的一种，之所以称之高效是因为通过对沉淀池体合理改造，采用分散颗粒的浅层沉淀理论，并吸收了国内外多层、多格、斜板沉淀先进技术。

广泛应用于冶金、市政工程、机械、化工、电力等行业的污水处理工程。

The high efficiency sediment tank belongs to one of sedimentation & separating devices. The reason why we called it high efficiency is that the tank has been reasonably rebuilt, the theory of scattering trains and sedimentation on shallow layer is adopted, as well as the advanced techniques at home & abroad—multilayer, multi grid and slant plate sediment—is absorbed.

It is widely applicable for the waste water and sewage in metallurgy municipal engineering, machinery, chemical industry, electric power and other trades.

● 技术性能参数 Technical Parameters

参数	型号	XCQ-90	XCQ-135	XCQ-250
进水SS(mg/L)			<1000	
出水SS(mg/L)			30-50	
几何容积(m ³)		80	125	198
进水管(mm)		DN150	DN200	DN350
出水管(mm)		DN150	DN350	DN500
排泥机功率(kW)		5.5	5.5	5.5
质量(t)		20	26	35
运行质量(V池)		100	150	235

● 外形结构 Outlines and Constructions

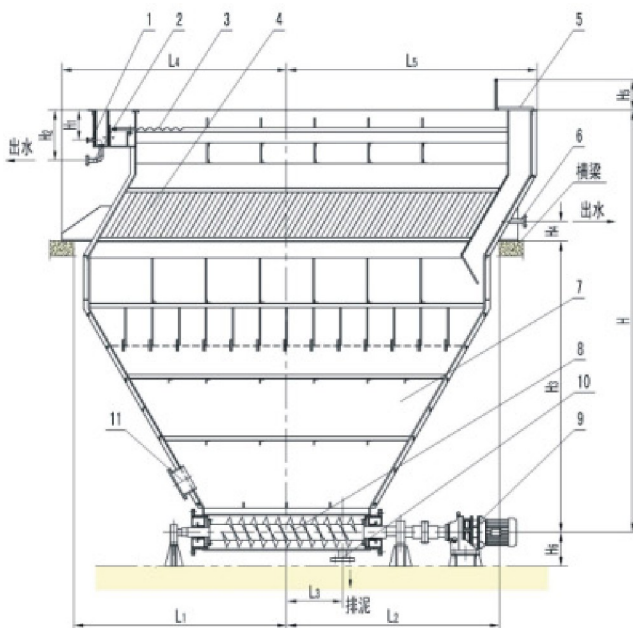

- 1-取样管
- 2-出水管
- 3-溢流堰
- 4-斜板
- 5-走道及栏杆
- 6-进水口
- 7-装置本体
- 8-螺旋排渣机
- 9-传动装置
- 10-排泥口放空管
- 11-人孔

● 型号示例 Type and Its Indication

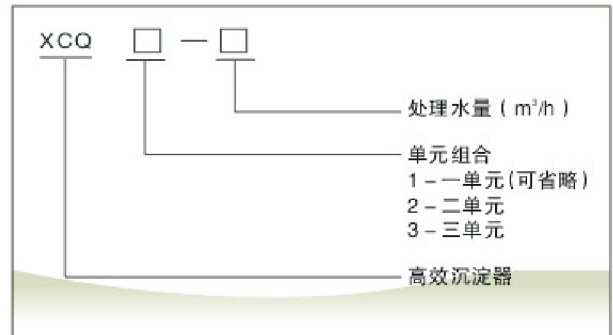

● 特点 Features

- 水力负荷高 (6.8 ~ 8.4m³/m² · h)。
 - 沉淀器排出泥浆浓度高 ≥ 50%，加之配用泥浆脉冲气流输送，可输送高浓度泥浆，不会堵管，无需冲洗。
 - 每个单元体分：90t/h、135t/h、250t/h，可以多元化组合，设计选用方便合理。
 - 加装斜管填料，提高沉淀效率。
- The hydraulic load is high(6.8 ~ 8.4m³/m² · h).
 - The density of impulse mud pneumatic conveyor, it can convey the mud with high density, the pipe will not be obstructed so it is not necessary to wash the pipe
 - The unit type is: 90t/h、135t/h、250t/h, which can be combined into diversification. Design and choosing is convenient and reasonable.
 - Installed with slop pipes filler, which can improve sedimentation efficiency.





● XCQ型尺寸参数 Size Parameters for Type XCQ

(mm)

尺寸 型号	H	H ₁	H ₂	H ₃	H ₄	H ₅	H ₆	L ₁	L ₂	L ₃	L ₄	L ₅
XCQ-90	6905	400	1205	4650	200	1000	500	2670	2670	1345	3100	2970
XCQ-135	7250	500	1300	4550	300	1000	500	3180	3180	1345	3710	4020
XCQ-250	7850	600	1400	5150	400	1000	500	3680	3680	1345	4205	4502

● XCQ₃型三元组合形式 TYPE-XCQ₃ Triad Group Combined Mode

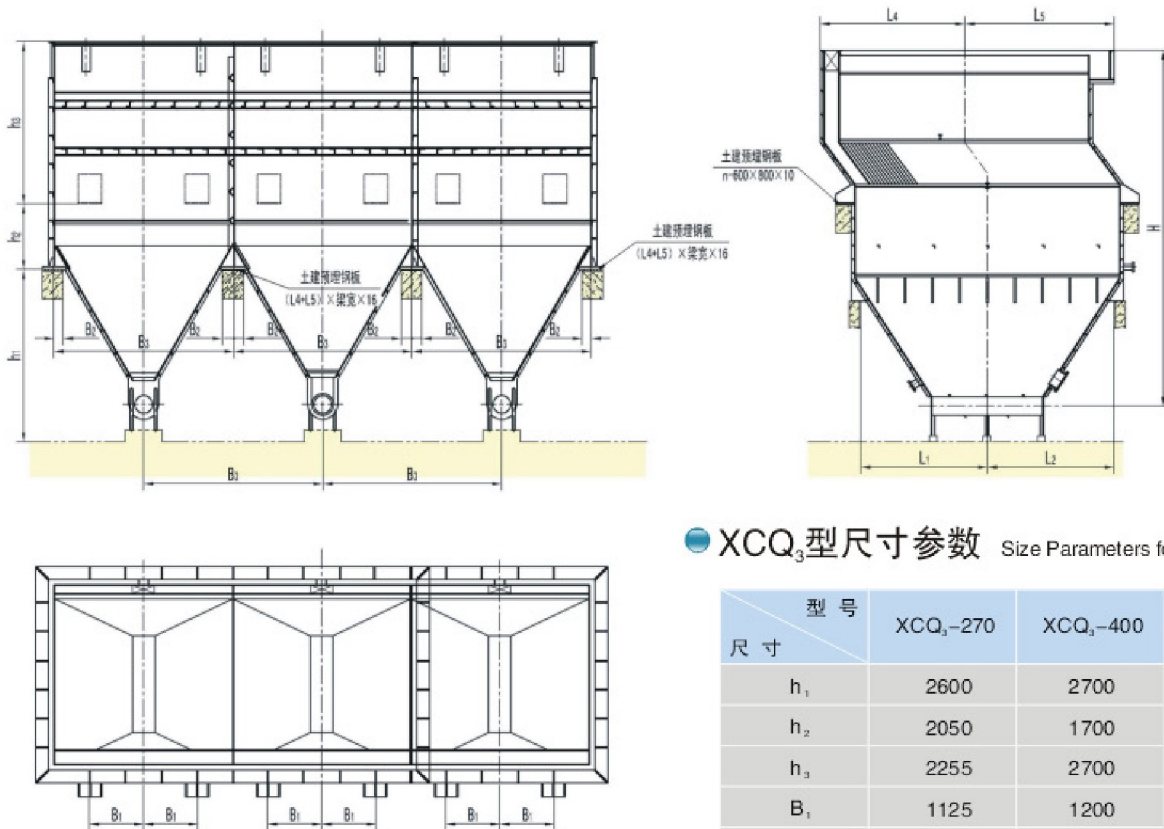

● XCQ₃型尺寸参数 Size Parameters for Type XCQ₃

(mm)

型号 尺寸	XCQ ₃ -270	XCQ ₃ -400	XCQ ₃ -750
h ₁	2600	2700	2700
h ₂	2050	1700	1700
h ₃	2255	2700	3450
B ₁	1125	1200	1700
B ₂	250	250	250
B ₃	4000	4000	5000

● 订货说明 Requirements for Order

1. 订货时应根据不同水量进行有机组合, 并应详细注明。
2. 土建部分设计负荷应参照表中数据, 如需钢制结构另订。
3. 需配套供应爬梯、工作桥以及脉冲气流输送器等, 订货时应注明。
4. 如需水质加药设备等, 请参考相关样本。

1. When ordering, should make an organic combination according to the different water volume and make a notification in detail.
2. For the designing load of the civil engineering part, should consult the data listed in the parameter table. If steel structure is needed, place an extra order.
3. When climbing ladder, working bridge and impulse pneumatic conveyor are needed to match, should indicate them.
4. About the equipment of adding chemical agents for water quality, please consult the relevant samples.